

U760E

APPLICATION

2009-13 TOYOTA CAMRY L4 2.4, 2.5L
2008-13 TOYOTA HIGHLANDER L4 2.7L
2010-13 TOYOTA SIENNA L4 2.7L
2011 TOYOTA VANGUARD L4 2.7L
2008-13 TOYOTA VENZA L4 2.7L
2011-13 SCION tC L4 2.5L

REBUILDING KITS

OVERHAUL: K75900S*
K75900SX+
BANNER: K7500SW/O*
K7500SXW/O+
MASTER: K7500S*
K7500SX+
PISTON KIT: K75900S-99
RING KIT: K75300Q
FRICTION MODULE: K7500S-1F
STEEL MODULE: K7500S-1S
* - W/ PISTON
+ - W/O PISTON

DISTINGUISHING CHARACTERISTICS

THERE MAY BE SLIGHT VARIATIONS FROM MODEL TO MODEL, BUT OVERALL CASE CONFIGURATION IS THE SAME

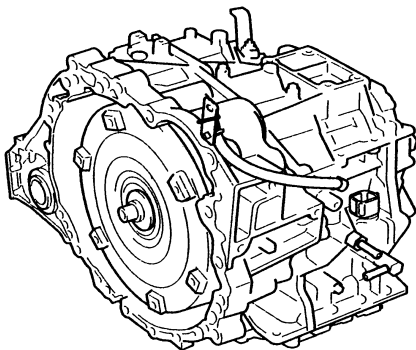

AVAILABLE COMPONENTS

FILTER
75575W
METAL CLAD SEALS
75235-PUMP
89028-AXLE (DIFF SIDE) 2WD
75348-AXLE (DIFF SIDE) AWD
75069-AXLE (CASE SIDE)
75401-TRANSFER ADAPTER (AWD ONLY)
48204-MANUAL CONTROL SHAFT
PAN GASKETS
75710LXD
BUSHINGS
75088-PUMP TO CONVERTER

BENEFITS

- 1 AVAILABLE BOTH WITH AND WITHOUT PISTONS
- 2 OEM COMPARABLE MATERIAL ON ALL COMPONENTS
- 3 CONVENIENTLY SUB-PACKAGED FOR EASE OF LOCATION AND INSTALLATION
- 4 FULL COMPLEMENT OF VALVE BODY CHECKBALLS, SCREENS AND CHECK ASSEMBLIES
- 5 CONTAINS SEALS FOR AWD APPLICATIONS

THE PROBLEM SOLVERS

PRECISION INTERNATIONAL ~ 14 TODD COURT EXT., YAPHANK, NY 11980
800.872.6649 ~ 631.567.2000 ~ sales@transmissionkits.com ~ www.transmissionkits.com

